

3.2.2 Silicon for Solar Cells

Personal "Historical" Remarks

- Having worked in the development of solar **Si** from **1977** up to the present day, I remember a sizeable number of projects that tried to make progress in the following areas:
 - Making "**solar-grade**" **Si** in *cheaper* ways than with the conventional process used for microelectronics **Si**.
 - Transform solar grade **Si** *directly* (no cutting) into suitable substrates for **solar cells** (square or hexagonal plates, rectangles, or ribbons; typically about **0,5 mm - 0,3 mm** thick) at low costs - meaning minimal losses of the starting material and simple processes.
 - Making solar cells out of the substrates at *low costs* - but with very good performance.
- The ingenuity - not to mention the money - that went into solving these questions is nothing less but amazing. There were (and still are) a large number (far more than anybody could have imagined) of approaches that have been tried - and most have been abandoned by now!
 - While recalling all these "failures" is not exactly necessary in the context of this lecture, it would be highly educational in a general context of alternative energy development. A quick scan of the readily available literature (including some **1000** pages of the proceedings of the international conference on solar energy (Vienna, **1998**) and **7** books) showed that many of the "old" approaches seem to be forgotten.
 - I will not make a concentrated effort to write the historical review that I could not find in the general literature in this Hyperscript. Only a few general remarks, illustrated by some readily available examples (to me), will be given in the backbone part. However, I might start some modules in the "advanced" section in which more historical stuff will be collected in due time.

General Requirements for Si Solar Cells

- A "[solar cell primer](#)" explaining briefly some of the more basic features of solar cells and solar energy, can be found in the link.
- When considering solar cells, all that counts in the end, is the *prize for 1 kWhr electricity* produced with the device. While it is not particularly easy to come up with this number, it is of course directly related to the production costs of **solar cell modules** (the assembly of solar cells in a frame) and thus to production costs of a single solar cell.
 - The costs of a module - typically **(1-2) m²** in size - can be broken down into three main components:
 - 35%** for the solar **Si** material (ready for cell production)
 - 30%** for the solar cell technology (making a solar cell)
 - 30%** for module manufacture.
 - If one uses the conventional process to make single crystalline wafers as the starting material for solar cells, the costs can be broken down as follows:
 - 30%** Starting material (**poly-Si**)
 - 35%** Crystal growth
 - 30%** Sawing the crystal into wafers (which also turns almost **1/2** of the expensive crystal into saw dust!)
 - 5%** for refining (etching, polishing, cleaning).
 - In other words: While **2/3** of the costs are directly caused by **Si** and **Si** technology, there is no overwhelming single cost factor - you have to work from all angles to reduce costs.
- How large is the **market** for **Si** solar cells?
 - In **1998** solar cells based on crystalline Si producing **130 MW_p** (the index "**p**" refers to "peak" power) electrical power were sold, another **20 MW_p** or so was based on amorphous Si.
 - Considering that **1 m²** of a solar module - very roughly - produces about **100 W_p**; this translates into **1 300 000 m²/a** of solar **Si**, or - with an average thickness of **300 μm** - into **390 m³** of **Si**, or - with a density of **2,33 g/cm³** - into **675 to/a** of **Si**.
 - The world production of semiconductor grade "raw" **Si** is roughly **20 000 to/a** (at very roughly **\$50/kg** equalling **1 G\$/a**; while the wafer business grosses something like **5 G\$/a**). Solar **Si** thus accounts for less than **5%** of the eligible **Si** production - small wonder that solar **Si** is usually taken from the "left over" of the microelectronic business. *Use [this link](#) for somewhat newer information about these topics.*
 - More and [newer numbers](#) can be found in the link.
- The growth rate of solar **Si**, however, is larger than the growth rate of **Si** for microelectronics. Sooner or later, the solar **Si** community will have to make its own **Si** and this will be a major milestone in the history of **Si** production.
- Let's now look at some of the major processes on the road from sand to solar modules:

"Solar Grade" Starting Material

As mentioned above, starting materials for solar **Si** is usually recruited from "left over" of microelectronic **Si** (**ME-Si**)

- Those "left over" might be wafers that were rejected, the seed- and end cones of the crystals, or parts of crystals that did not meet specifications.
- Some former **ME-Si** producers, no longer able to compete (i.e. **Si** producers from the former **UDSSR**), now sell their products as "cheap" solar **Si**.
- "Cheap" does not mean "dirty" or otherwise degraded with respect to the life time or diffusion length. A "good" diffusion length **L** of the minority carriers (say at least a **100 μm**) is absolutely mandatory. What this means in terms of permissible impurities was [shown before](#), here similar data are displayed directly for solar cell performance.

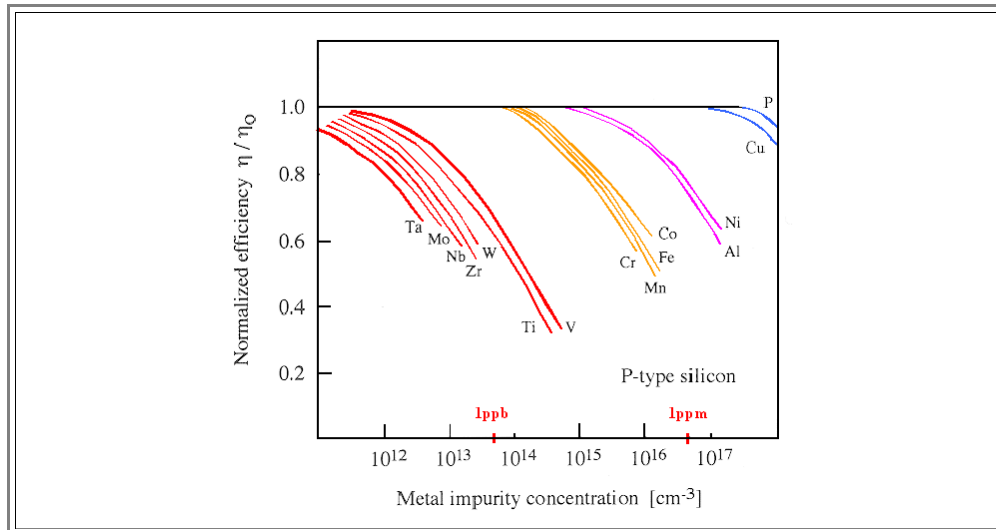

Efforts to produce dedicated solar **Si** *directly*, essentially can exploit three ways:

1. Take cheap metallurgical grade **Si** (**MG-Si**) and find a cheaper process than [the standard process](#) to convert it to **poly-Si**. Many attempts have been made; but nothing seems to work so far.
2. Use the process for making **MG-Si**, but use sufficiently pure **SiO₂** and **C**, which will lead to relatively pure **Si** directly usable as the starting material for making solar cells. The trick is to obtain the clean ingredients cheaply (this could mean that you must make them yourself). Siemens AG spend quite some time (and money) exploring this route. The approach worked, but not necessarily cheaply, and was abandoned about **1985**.
3. Use a different reduction process for **SiO₂**. The only competitor, it appears, is the **aluminothermic reduction**

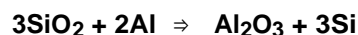

- Since **Al** is an acceptor, the resulting **Si** can be expected to be strongly **p-doped** - not acceptable for **ME-Si**, but fine for solar **Si** (which we want **p-doped** anyway).
- While it is not directly obvious why this process should be better (mostly meaning cheaper) than the conventional process, it has been developed by Bayer AG and is ready for production - but is not used at the present time (Nov. **2000**).

Whichever way you produce your solar **Si**, next you must make thin sheets or slices (the name "wafer" is reserved for the **ME-Si** product), possibly by first converting your solar **Si** to something bulky material, or by making "flatware" directly. Typically you want a **10 cm x 10 cm x 0,03 cm** slice of **p-doped Si** for the production of the individual solar cells. This is probably the field where most new methods were developed as outlined below.

Cutting Slices from Bulk Si

▶ This is the main technology for making commercial **Si** solar cells. There is a bewildering multitude of processes, but all belong to two basic classes:

▶ **Conventional" Technologies** : Grow a (mostly single) crystal and slice it. This version accounts for (roughly) one half of solar cells sold today (Nov 2000). Compared to **ME-Si**, money can be saved along the following lines:

- Use less pure **poly-Si** and grow the crystal with relaxed specifications. Allow larger concentrations (and especially concentration variations) of dopant, oxygen, some impurities and tolerate some dislocations.
- This allows for higher growth rates - after all it is the amount of **m²/min** of solar cell material that defines the productivity of your factory and thus determines how many (expensive) crystal pullers you must have.
- Some special tricks include the growth of "tri"-crystals (three single crystals joined by defined grain boundaries, or the growth of crystals with hexagonal cross section).
- Slicing the crystals with inner-diameter diamonds saws - the conventional way for **ME-Si** - takes time and wastes a lot of **Si**, but produces superior flatness which, however, is not needed for solar cells. **Wire saws** with many parallel wires are used instead.
- Polishing to a mirror finish - de rigeur for **ME-Si** - is abandoned in favor of a chemical etching procedure that simply removes the layer damaged by the cutting.

▶ **Casting** - followed by slicing; or casting directly into some kind of flat shape. The first version is now a standard technique, it accounts for (roughly) the other half of the **Si** solar cells sold today. If you think that casting **Si** seems to be an obvious and easy way for cheap production - you are dead wrong: Casting **Si**, in contrast to practically all metals, is **very difficult** because:

- **Si expands** by almost 10 % upon solidification - almost everything else contracts. What happens then is known from water (**H₂O**) which is one of the few substances with the same "**melting point anomaly**": Your water pipes and hoses, if left with freezing water in the winter, will explode without fail - the pressure built up during solidification will easily destroy almost any container. The only way left for casting is to make sure that you have a **directional solidification** - the liquid **Si** must always be on top of the solidified one and **never** trapped inside something.
- **Si sticks to the walls** of the mold because it is still under internal pressure (if it would contract like most other materials, it would retract from the walls) **and** it reacts with almost anything. Getting it out of the mold (which you would like to reuse) is not easy and calls for special materials and procedures.

▶ Casting thin sheets in moulds therefore is practically impossible - what has been tried is:

- "**Spin casting**", pioneered by the Hoxan Corp., Japan. Here a drop of molten **Si** falls on the center of a rapidly spinning wheel so that the liquid **Si** is immediately pulled out to a thin sheet which then crystallizes. Solar cells of good quality have been obtained; but it remains to be seen if the process makes it to large scale production.
- "**Band casting**" by rapid quenching in analogy to the production method of amorphous metals. A constant stream of a molten **Si** jet impinges on a rapidly turning cooled metal wheel. The **Si** solidifies rapidly and a thin continuous band (at speeds of several **m/s**) is produced. The technique has been tried in a cooperation of Siemens and "Vacuumschmelze Hanau", but the resulting **Si** bands were of poor quality and nothing came from it.

▶ The method of choice then is casting big blocks of (necessarily) poly-crystalline **Si**, slice them with a wire saw, and make solar cells as as best as you can - considering that the material contains grain boundaries and lots of other defects which are generally detrimental to the performance of solar cells.

- Several companies - most prominently "**Bayer Solar**", a company formed of the two formerly independent producers Wacker Chemitronic and Bayer AG, but also several other companies, produce poly-crystalline solar **Si** in this way which is often sold to other companies that produce the solar cells.
- All possible problems notwithstanding - good solar cells with efficiencies of **12% - 14%** are routinely manufactured and this is not much worse than what one would get with single crystalline **Si** and standard processes. [An example](#) is shown in the link.

Conversion to "Flat" Silicon

▶ Cutting crystals of any kind into slices is wasteful and expensive - large scale efforts to convert solar grade **Si** to "flat" **Si** in one fell swoop thus has been (and still is) a constant in the world of **Si** solar cells since about 1975. Usually "flat" means some kind of long ribbon, but defined rectangles (or, as in the case of the melt spinning mentioned above), round "wafers" were also considered.

▶ Many different ways were explored - few are still with us, and only one (? I'm not quite sure about this) has made it to a production status - the "**EFG**" process, see below.

▶ A basic classification of the many ways is:

- Technologies **not using a substrate** of some kind - producing "free standing" **Si** ribbons

- Technologies using a **substrate** of some kind - producing **Si** layers on some other material or free-standing **Si** after separation from the substrate.

The **first category** contains tricky crystal growth methods like:

Dendritic web growth: A pretty much single crystal sheet is grown from the melt (not unlike the conventional **CZ** procedure), except that growth is restricted to a thin sheet expanded between two somewhat thicker **Si** "dendrites" as illustrated below.

- This is something for experts in crystal growth techniques; it was tried, worked, and produced good solar cells - but it was abandoned (too expensive).
- Below a few schematic sketches of what is involved.

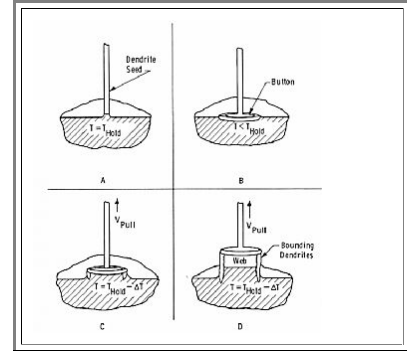
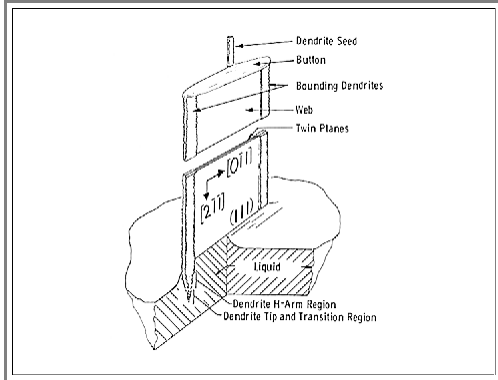

Ribbon growth directly from the melt by pulling out the crystal in an horizontal arrangement - sort of "over the rim".

- The solidification interface is steeply inclined and thus rather large which makes it easier to remove the heat of crystallization; high growth rates have been achieved.
- However, this is a tricky process difficult to run stable for a long time. And if anything goes wrong, it is very time consuming to start it again. In summary: Too expensive.
- Variants have been tried, too; below three basic principles without any further comment.

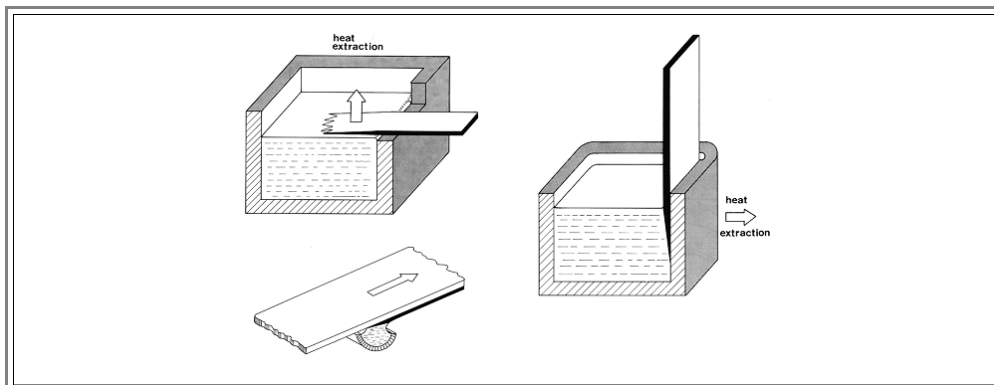

The "**EFG**" method, i.e. the "**Edge defined film-fed crystal growth technique**". This is the one (and so far only (?)) method that made it to production scale. It was started by an offspring of Mobile (oil company) called Mobile Tyco, but now is owned by **ASE**, a German based Company.

- In essence, it is a modified **CZ** crystal growth technique. The crucible filled with liquid **Si** contains a (graphite) die or nozzle and the crystal is pulled from a thin slot on top of the nozzle; well above the level of the liquid **Si** in the crucible.
- The **Si** used up in the crystallization is fed through capillary action to the surface of the nozzle. This looks schematically like this:

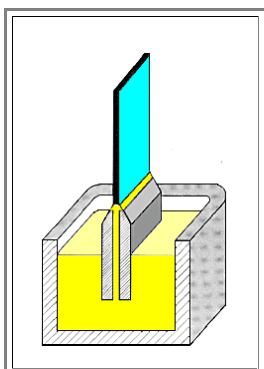

- Relatively long ribbons of good quality could be made after several years of development.
- The process was improved and became more economical by "bending" the die into a closed form, for reasons not clear to me preferably into a nonagon. The nine-sided tube is then cut along the edges and good quality material (almost, but not quite single crystalline) is obtained (if good solar **Si** is used as feedstock). Presently developments are under way to grow tubes with about **1m** in diameter!

▶ The *second category* contained the following methods:

▶ The "**S-web**" technique from Siemens AG (my first job at Siemens).

- Here a net (mesh about **5 mm**) from high-purity carbon fibres (not cheap) is led through a solar-**Si** melt. The idea was that liquid **Si** is drawn out in the meshes of the net and stabilized by its high surface tension. It then can crystallize at leisure - the sheet forming process and the crystallization process are essentially decoupled and the removal of the heat of crystallization is no longer the limiting factor in "productivity" (= m_2 of **Si/min**)
- The basic principle is shown below; it can be used for a variety of substrates, not only for carbon nets, but also, e.g. for carbon "paper" (tried by a french group in the eighties) or ceramic substrates.

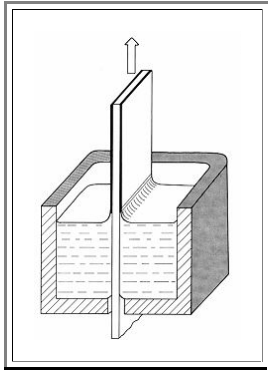

- Of course, everything can be combined. **S-webs** were pulled out of dies, or by moving the net horizontally over the melt.

- Well, the **S-web** technique did not work as originally envisioned - but it worked eventually! Long ribbons grown at high speed (up to **1m/min**) and up to **10 cm** in width could be grown; the pictures show an example. The remains of the net (it turns into **SiC**) on the backside are clearly visible on the right-hand side view.

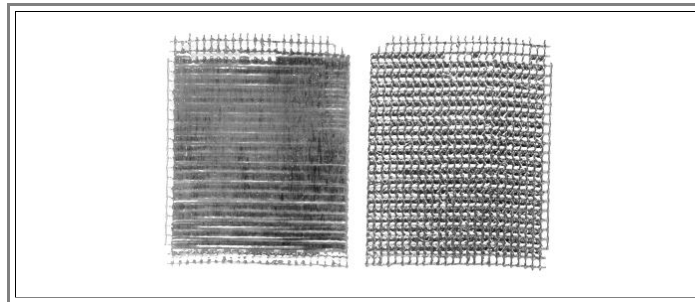

- Amazingly enough, the crystal quality was not as bad as it could have been - the net did not induce a lot of defects like dislocations etc. - and solar cells with efficiencies **> 10%** have been made from **S-web** material.
- But as ever so often - there was no real advantage in prize and the technology was abandoned around **1985**. That was also true for most of the other methods touched upon above, (and for several methods not even mentioned).

▶ What do we learn from this? It is not so easy to make cheap solar cells from crystalline **Si**! Many billions of \$ have been spent on the effort, and untold master- and PhD theses were written. But much has been learned and the search goes on - with different materials, but also new ideas for crystalline **Si**.

Specialities

▶ A rapidly growing segment in the research part of solar energy are "**Thin film Si solar cells**"

- Here a "thin" film (actually several μm to **15 μm** thick, i.e. not "thin" in the usual meaning of micro electronic technology) of **poly-Si** is deposited on a suitable substrate (e.g. some glass with a layer of **ITO** for the necessary electrical contact), a **pn**-junction and a contact is added to obtain a solar cell.
- Since the cell is too thin to absorb all radiation in the infrared, the surfaces (or interfaces) should be textured and contain lots of microrprisms which reflect the radiation back into the **Si**.
- This topic will be covered in more detail in [the seminar](#)

▶ Several groups (Canon, Sony and a research institute of the University of Stuttgart) use **Porous Si** in conjunction with **Waferbonding** to make solar cells.

- *(to be filled in later)*

▶ Not so obvious approaches were:

- Production of suitable **Si** plates by **sintering** fine **Si** powder - akin to the standard process for making ceramics. This was a process pursued by Siemens in the early eighties and then carried over to a research Institute in Freiburg/Germany. While it works, it does not seem to offer clear advantages and was abandoned
- Produce **spherical solar cells** by making small spheres (in the **mm** range) of **Si** that contain a **pn**-junction on the outside (let drops of liquid **Si** fall down a tower (in vacuum of course) and add some dopant gases near the bottom). Then fuse the little spheres to flexible sheets, provide contacts (tricky!) - and you have a big solar cell, a whole module, in fact.
- This process was pioneered by Texas Instruments (to some extent, it appears, because it was the brain child of Jack **Kilby**, the famous co- inventor of the integrated circuit who just (**2000**) got the Nobel prize (the other inventor was Robert **Noyce** from Fairchild (which spawned Intel among many other companies)). While highly advertized in the late eighties and early nineties, it was recently sold to "Ontario Power" (where I lost its trace).