

3.4. Dynamic Properties

3.4.1 Dielectric Losses

The electric power (density) L lost per volume unit in any material as heat is *always* given by

$$L = j \cdot E$$

With j = current density, and E = electrical field strength.

In our ideal dielectrics there is *no direct current*, only **displacement currents** $j(\omega) = dD/dt$ may occur for alternating voltages or electrical fields. We thus have

$$j(\omega) = \frac{dD}{dt} = \epsilon(\omega) \cdot \frac{dE}{dt} = \epsilon(\omega) \cdot \frac{d[E_0 \exp(i\omega t)]}{dt} = \epsilon(\omega) \cdot i \cdot \omega \cdot E_0 \cdot \exp(i\omega t) = \epsilon(\omega) \cdot i \cdot \omega \cdot E(\omega)$$

(Remember that the dielectric function $\epsilon(\omega)$ includes ϵ_0).

With the dielectric function written out as $\epsilon(\omega) = \epsilon'(\omega) - i \cdot \epsilon''(\omega)$ we obtain

$$j(\omega) = \omega \cdot \epsilon'' \cdot E(\omega) + i \cdot \omega \cdot \epsilon' \cdot E(\omega)$$

real part of $j(\omega)$; in phase	imaginary part of $j(\omega)$ 90° out of phase
---	---

That part of the displacement current that is *in phase* with the electrical field is given by ϵ'' , the *imaginary* part of the dielectric function; that part that is **90° out of phase** is given by the *real* part of $\epsilon(\omega)$. The power losses thus have two components

Active power¹⁾

$$L_A = \text{power really lost, turned into heat} = \omega \cdot |\epsilon''| \cdot E^2$$

Reactive power

$$L_R = \text{power extended and recovered each cycle} = \omega \cdot |\epsilon'| \cdot E^2$$

1) Other possible expressions are:

actual power, effective power, real power, true power

Remember that active, or effective, or true power is energy deposited in your system, or, in other words, it is the power that heats *up your material!* The reactive power is just cycling back and forth, so it is not heating up anything or otherwise leaving direct traces of its existence.

The first important consequence is clear:

We can heat up even a "perfect" (= perfectly none DC-conducting material) by an AC voltage; most effectively at frequencies around its resonance or relaxation frequency, when ϵ'' is always maximal.

Since ϵ'' for the resonance mechanisms is directly proportional to the friction coefficient k_R , the amount of power lost in these cases thus is directly given by the amount of "friction", or power dissipation, which is as it should be.

It is conventional, for reason we will see immediately, to use the quotient of L_A / L_R as a measure of the "quality" of a dielectric: this quotient is called "**tangens delta**" (**tg δ**) and we have

$$\frac{L_A}{L_R} := \text{tg } \delta = \frac{I_A}{I_R} = \frac{\epsilon''}{\epsilon'}$$

- Why this somewhat peculiar name was chosen will become clear when we look at a pointer representation of the voltages and currents and its corresponding equivalent circuit. This is a perfectly legal thing to do: We always can represent the current from above this way; in other words we can always model the behaviour of a real dielectric onto an **equivalent circuit diagram** consisting of an *ideal* capacitor with $C(\omega)$ and an *ideal* resistor with $R(\omega)$.

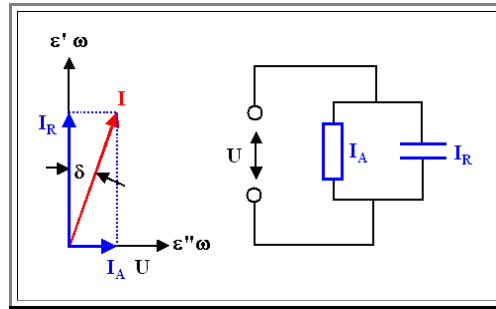

- The current I_A flowing through the *ohmic resistor* of the equivalent circuit diagram is in phase with the voltage U ; it corresponds to the imaginary part ϵ'' of the dielectric function times ω .
- The 90° out-of-phase current I_R flowing through the *"perfect" capacitor* is given by the real part ϵ' of the dielectric function times ω .
- The numerical values of both elements must depend on the frequency, of course - for $\omega = 0$, R would be infinite for an ideal (non-conducting) dielectric.
- The smaller the angle δ or $\tan \delta$, the better with respect to power losses.
- Using such an **equivalent circuit diagram** (with always "ideal" elements), we see that a *real* dielectric may be modeled by a fictitious "ideal" dielectric having no losses (something that does not exist!) with an ohmic resistor in parallel that represents the losses. The value of the ohmic resistor (and of the capacitor) must depend on the frequency; but we can easily derive the necessary relations.
- How large is R , the more interesting quantity, or better, the *conductivity* σ of the material that corresponds to R ? Easy, we just have to look at the equation for the current [from above](#).
- For the in-phase component we simply have

$$j(\omega) = \omega \cdot \epsilon'' \cdot E(\omega)$$

- Since we *always* can express an in-phase current by the conductivity σ [via](#)

$$j(\omega) := \sigma(\omega) \cdot E(\omega)$$

- we have

$$\sigma_{DK}(\omega) = \omega \cdot \epsilon''(\omega)$$

- In other words: The dielectric losses occurring in a perfect dielectric are completely contained in the imaginary part of the dielectric function and express themselves as if the material would have a frequency dependent conductivity σ_{DK} as given by the formula above.
- This applies to the case where our dielectric is still a *perfect* insulator at **DC** ($\omega = 0$ Hz), or, a bit more general, at low frequencies; i.e. for $\sigma_{DK}(\omega \rightarrow 0) = 0$.
- However, nobody is perfect! There is no *perfect* insulator, at best we have *good* insulators. But now it is easy to see what we have to do if a *real* dielectric is *not* a perfect insulator at low frequencies, but has some finite conductivity σ_0 even for $\omega = 0$. Take water with some dissolved salt for a simple and relevant example.
- In this case we simply *add* σ_0 to σ_{DK} to obtain the total conductivity responsible for power loss

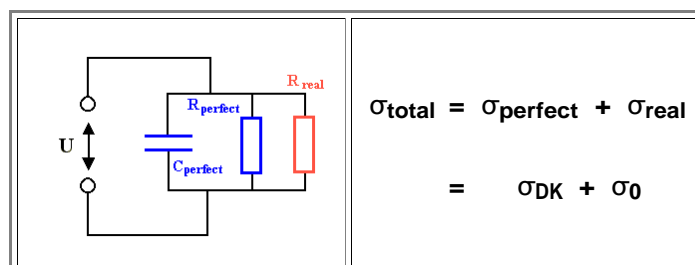

- Remember: For resistors in parallel, you **add** the conductivities (or $1/R$'s) ; it is with **resistivities** that you do the $1/R_{total} = 1/R_1 + 1/R_2$ procedure.

Since it is often difficult to separate σ_{DK} and σ_0 , it is convenient (if somewhat confusing the issue), to use σ_{total} in the imaginary part of the dielectric function. We have

$$\epsilon'' = \frac{\sigma_{total}}{\omega}$$

- We also have a completely general way now, to describe the response of **any** material to an electrical field, because we now can combine dielectric behavior and conductivity in the complete dielectric function of the material.
 - Powerful, but only important at high frequencies; as soon as the imaginary part of the "perfect" dielectric becomes noticeable. But high frequencies is where the action is. As soon as we hit the high **THz** region and beyond, we start to call what we do "**Optics**", or "**Photonics**", but the material roots of those disciplines we have right here.
- In classical electrical engineering at not too large frequencies, we are particularly interested in the relative magnitude of both current contributions, i.e in $\text{tg } \delta$. From the pointer diagram we see directly that we have

$$\frac{I_A}{I_R} = \text{tg } \delta$$

We may get an expression for $\text{tg } \delta$ by using for example the [Debye equations](#) for ϵ' and ϵ'' derived for the dipole relaxation mechanism:

$$\text{tg } \delta = \frac{\epsilon''}{\epsilon'} = \frac{(\epsilon_s - \epsilon_\infty) \cdot \omega / \omega_0}{\epsilon_s + \epsilon_\infty \cdot \omega^2 / \omega_0^2}$$

- or, for the normal case of $\epsilon_\infty = 1$ (or , more correctly ϵ_0)

$$\text{tg } \delta = \frac{(\epsilon_s - 1) \cdot \omega / \omega_0}{\epsilon_s + \omega^2 / \omega_0^2}$$

- This is, of course, only applicable to real **perfect** dielectrics, i.e. for real dielectrics with $\sigma_0 = 0$.

The total power loss, the **really interesting quantity**, then becomes (using $\epsilon'' = \epsilon' \cdot \text{tg } \delta$, because $\text{tg } \delta$ is now seen as a **material parameter**) .

$$L_A = \omega \cdot \epsilon' \cdot E^2 \cdot \text{tg } \delta$$

This is a useful relation for a dielectric with a given $\text{tg } \delta$ (which, for the range of frequencies encountered in "normal" electrical engineering is approximately constant). It not only gives an idea of the electrical losses, but also a very rough estimate of the break-down strength of the material. If the losses are large, it will heat up and this always helps to induce immediate or (much worse) eventual [breakdown](#).

We also can see now what happens if the dielectric is **not ideal** (i.e. totally insulating), but slightly conducting:

- We simply include σ_0 in the definition of $\text{tg } \delta$ (and then automatically in the value of ϵ'').
- $\text{tg } \delta$ is then non-zero even for low frequencies - there is a constant loss of power into the dielectric. This may be of some consequence even for small $\text{tg } \delta$ values, as the example will show:

The $\text{tg } \delta$ value for regular (cheap) insulation material as it was obtainable some **20** years ago at very low frequencies (**50 Hz**; essentially **DC**) was about $\text{tg } \delta = 0,01$.

- Using it for a high-voltage line ($U = 300 \text{ kV}$) at moderate field strength in the dielectric ($E = 15 \text{ MV/m}$; corresponding to a thickness of **20 mm**), we have a loss of **14 kW/m³** of dielectric, which translates into about **800 m** high voltage line. So there is little wonder that high-voltage lines were not insulated by a dielectric, but by air until rather recently!

Finally, some examples for the $\text{tg } \delta$ values for commonly used materials (and low frequencies):

Material	ϵ_r	$\text{tg } \delta$ $\times 10^{-4}$
Al ₂ O ₃ (very good ceramic)	10	5...20
SiO ₂	3,8	2
BaTiO ₃	500 (!!)	150
Nylon	3,1	10...0,7
Poly...carbonate, ...ethylene ...styrol	about 3	
PVC	3	160

And now you understand how the [microwave oven](#) works and why it is essentially heating only the water contained in the food.

Questionnaire

Multiple Choice questions to 3.2.1